



IMPACT RESISTANCE



NOISE

# FlexWrap® 3500

## Product Highlights

- Operating temperature up to +150°C (+302°F)
- Wrappable design for easy installation
- No installation tool required
- Excellent abrasion resistance
- Excellent cut through resistance
- Noise suppression
- Easily accommodates breakouts
- Excellent flexibility
- Secured positioning on application

## Typical Applications

- Body compartment wire harnesses
- Cable assemblies
- Tubings



Our manufacturing sites are certified ISO 9001, ISO/TS 16949, or AS/EN 9100, and ISO 14001

FW3500\_04262018



**FlexWrap® 3500** is a wrappable, damage-resistant sleeving designed to provide mechanical protection and acoustical noise suppression. Knit of monofilament and multifilament polyester yarns, the product offers a high level of component protection and is also very flexible.

FlexWrap 3500 is specially recommended for the bundling and the protection of wire harnesses, cable and tubing assemblies subject to extreme physical conditions.

The wrappable design of FlexWrap 3500 makes it easy to apply to areas restricted by large end fittings. The two adhesive strips give the double advantage of holding the sleeve in place on the application and being a secure closing system.

**BentleyHarris®**  
Protection Products

# Performance Data – FlexWrap® 3500

Property	Test Method	Result
Temperature Rating		+150°C (+302°F)
Heat Aging: 240 hrs. at +175°C (+347°F)	ISO 6722-1	Neither any visible degradation nor loss of flexibility. Shrinkage < 10%
Cold Bend Test	STL S21 5101	-40°C (-40°F)
Flammability	FMVSS 302 D45 1333	Pass Self extinguishing Type B
Noise Suppression	SAE J2192	Rubbing : -18 dB(A) Rattling : -40 dB(A)
Dynamic Cut Through	BS G212	Resistance superior at 3.5 kg

All numeric performance data shows average or typical values. Please consult your sales representative for product drawings, test reports and OEM approvals.

## Product Specifications

Commercial Part Number	Width mm	Size mm	Recommended Application Range mm	
			Min Ø	Max Ø
FlexWrap 3500 65-0/-	65	14	10	15
FlexWrap 3500 85-0/-	85	20	16	22
FlexWrap 3500 105-0/-	105	24	21	26
FlexWrap 3500 120-0/-	120	28	25	31
FlexWrap 3500 150-0/-	150	35	30	38

## Availability

FlexWrap 3500 is available in a range of sizes and cut to your specification. Standard color is black. Please contact your sales representative for availability.

## Construction

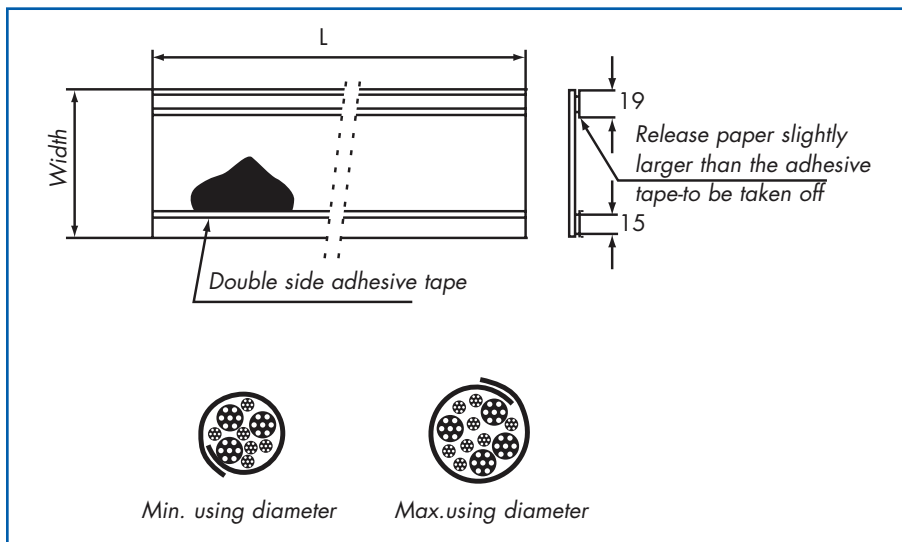

The information and illustrations given herein are believed to be reliable. Federal-Mogul makes no warranties as to their accuracy or completeness and disclaims any liability in connection with their use. Federal-Mogul's only obligations are those in the standard term of sale for this product and Federal-Mogul will not be liable for any consequential or other damages arising out of the use or misuse of this product. Users should make their own evaluations to determine the suitability of the product for specific applications.

©2007 Federal-Mogul Systems Protection, manufacturer of Bentley-Harris protection products.

**FEDERAL MOGUL**  
Systems Protection

**USA:** (1) 800 926 2472  
**Europe:** (33) 3 44 39 06 06  
**Japan:** (81) 45 479 0201  
**China:** (86) 21 6182 7688

[www.federalmogul.com/sp](http://www.federalmogul.com/sp)